



## GF501 SERIES (4kW)

---

5-Axis 3D Laser Cutting Head - User Manual



## Document History

| Edit date | Version | Topic, revision, action taken |
|-----------|---------|-------------------------------|
|           |         |                               |

laser

Raytools AG

Disclaimer

Use Regulations

Personnel Responsibilities

## Safety Instructions

Prevent Electric Shock



Guard against Danger



Laser Caution

Prevent Waterway Corrosion

Noise Prevention

Storage and Transportation





## 1. Overview

### 1.1 About this manual

### 1.2 Relevant File

### 1.3 Application



## 2. Sign and Description



.

.

.

.

## 3. Start-up Preparation

### 3.1 Power Supply

Caution: Only drives listed can be applied to meet different voltage requirements of motors.

### 3.2 Motor Safety Module

## 3.3 Motor Working Temperature

|  |  |  |
|--|--|--|
|  |  |  |
|  |  |  |
|  |  |  |
|  |  |  |



Caution: Please check the factory temperature thresholds of motors and set proper values. Failure temperature values may cause operating faults and overheating of motor.

## 3.4 Working Environment

|  |  |
|--|--|
|  |  |
|  |  |
|  |  |

## 3.5 Water Cooling



Caution: To avoid reducing the mechanical performance and damage to the cutting head parts (such as frameless motors), please note the following aspects:

### 3.5.1 Technical Data

|  |  |
|--|--|
|  |  |
|  |  |
|  |  |
|  |  |
|  |  |
|  |  |

|  |  |
|--|--|
|  |  |
|  |  |
|  |  |
|  |  |
|  |  |
|  |  |



Caution: If cooling water temperature is higher than 20°C, reduce Tc and Lc in the parameter setting.

3.5.2 Dew

3.5.3 Anti-rust

3.5.4 Water Contamination

3.6 Water Leakage

3.7 Clean Gas (Protective Gas)



Caution: Gas must be filtered and dried without contaminated liquid and mechanical particles, meeting the requirements of Class 3 in ISO 8573-1:2020.

Particle size :  $<5\mu\text{m}$ / $<<5\text{mg}/\text{m}^3$ ; Water/Pressure dewpoint:  $-20\text{ }^\circ\text{C}$ ; Oil:  $<<1\text{mg}/\text{m}^3$ .

3.8 AO Mirror Gas

3.9 Brake Gas



## 4. Technical Data

|  |  |  |  |
|--|--|--|--|
|  |  |  |  |
|  |  |  |  |
|  |  |  |  |
|  |  |  |  |
|  |  |  |  |
|  |  |  |  |
|  |  |  |  |
|  |  |  |  |

|  |  |  |  |
|--|--|--|--|
|  |  |  |  |
|  |  |  |  |
|  |  |  |  |
|  |  |  |  |
|  |  |  |  |
|  |  |  |  |

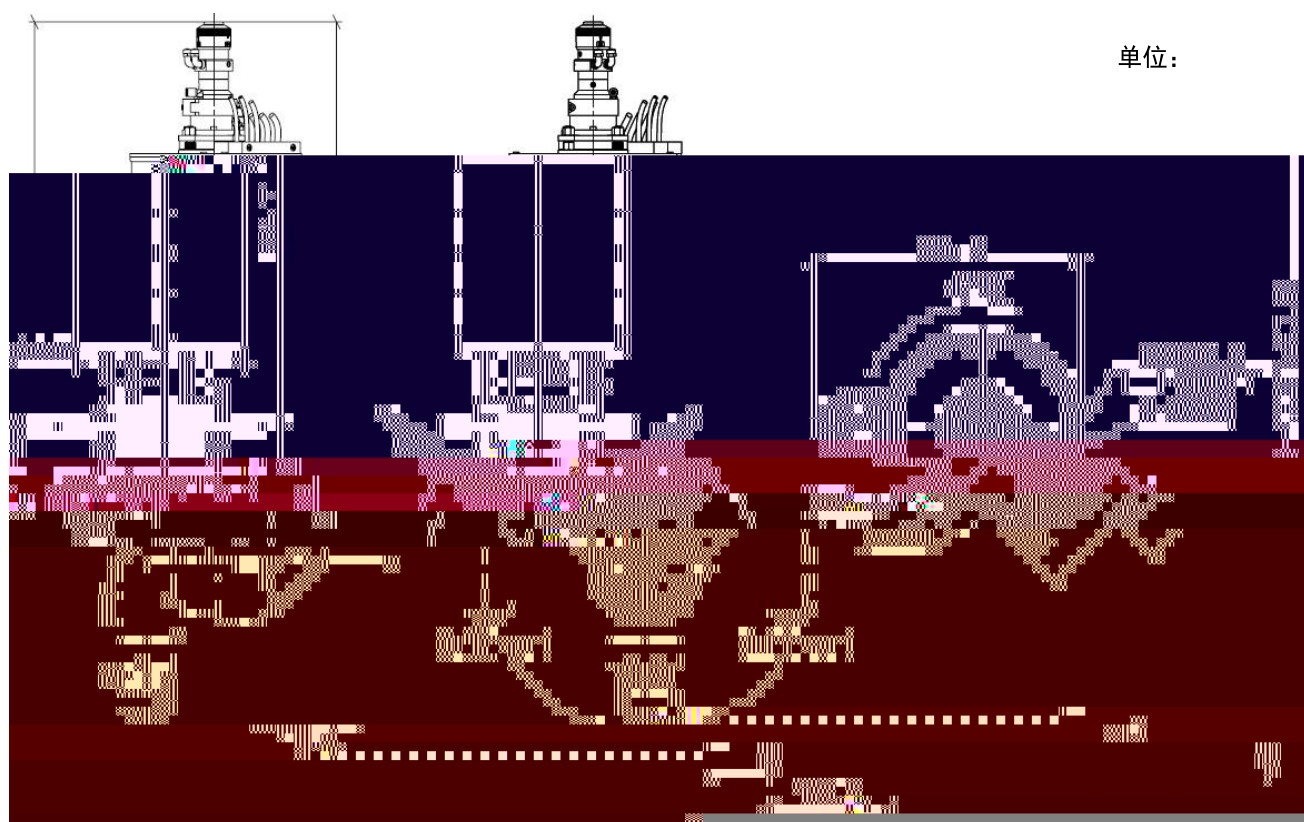

## 5.1.1 Levelling Preparation

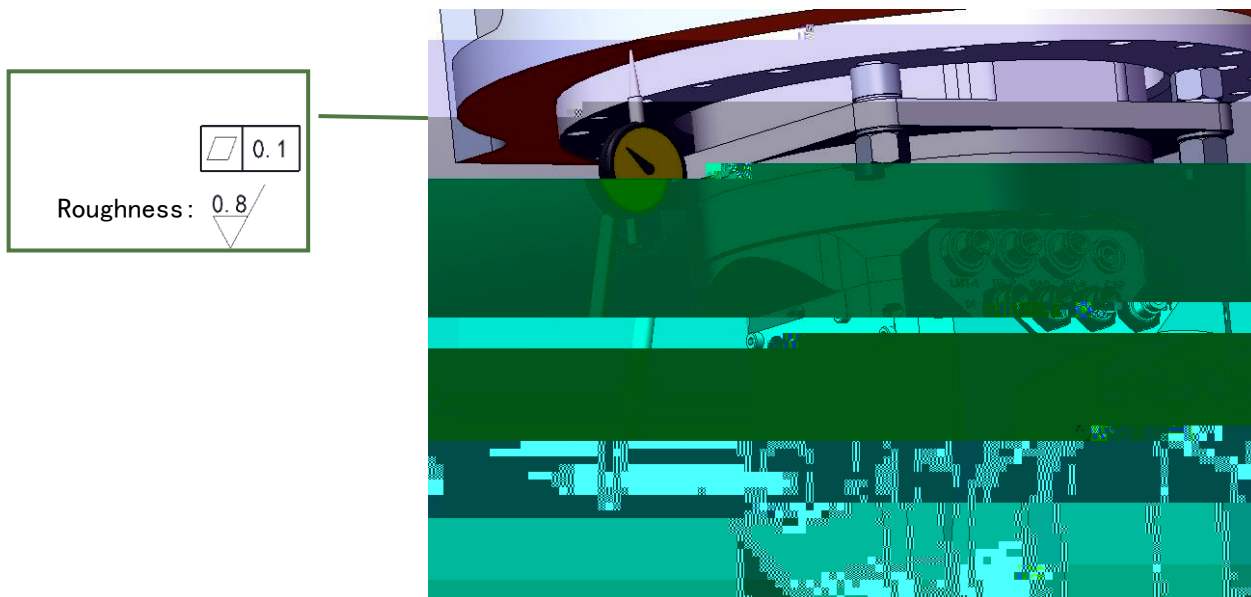
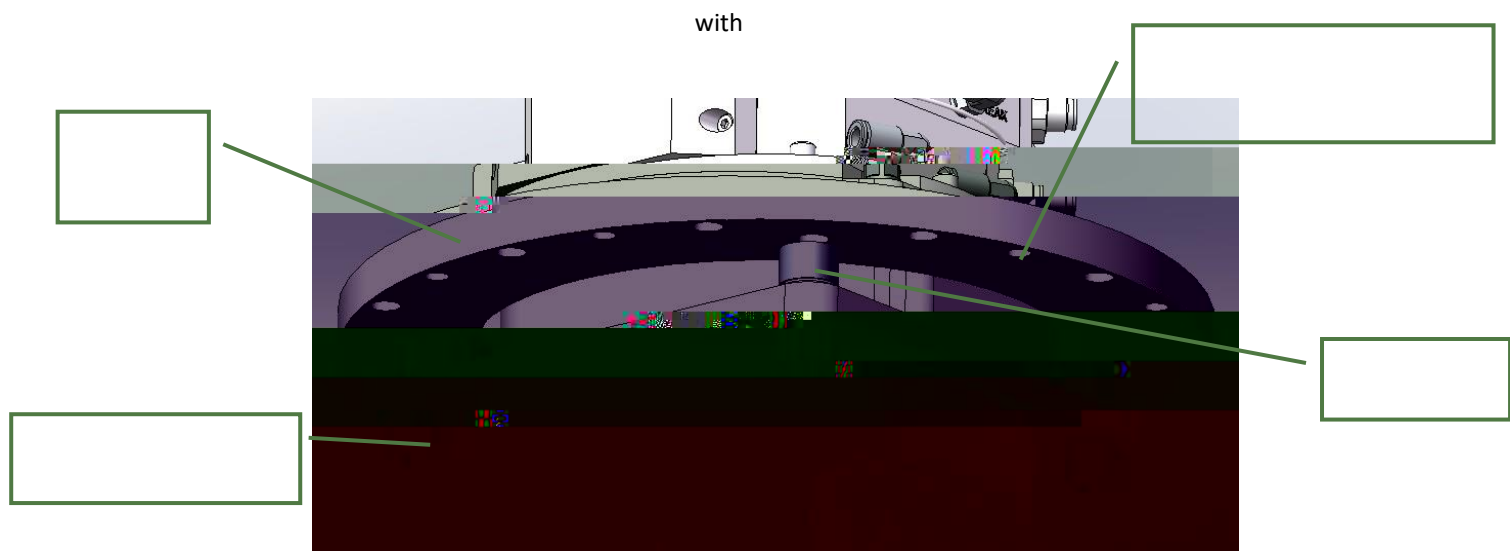



Note: Only loose nuts of a corner at a time to adjust its angle.

## 5.1.2 Levelling Method:

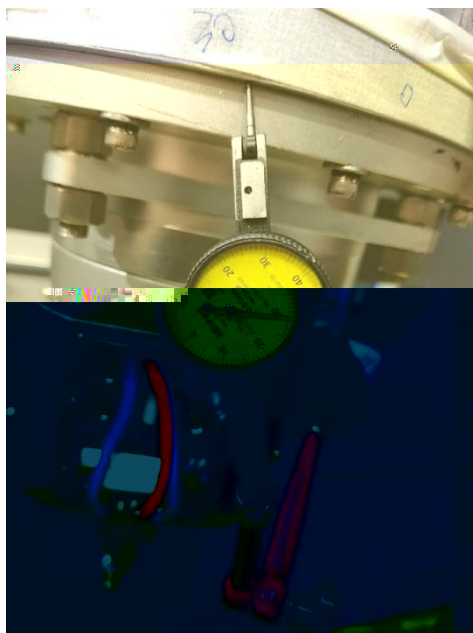

## 5.2 QBH Interface

### 5.2.1 Removal and Installation of QBH Interface

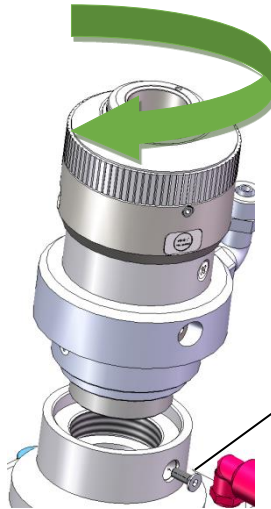

### 5.2.2 Connection of Laser



WARNING: The optical components must be dust free and all dusts must be cleaned before use. The fiber shall be horizontally inserted into fiber interface to prevent dust from entering the interface and falling on the surface of the lens. Upper limit in the fiber before fixing the laser head.

**Cover fiber interface with a white plastic dustproof cover when not using it to ensure a clean environment.**

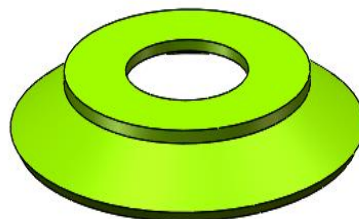



## 5.3 Optics System Adjustment



Note: Adjust optical path in a clean environment.

### 5.3.1 Collimation Module Adjustment

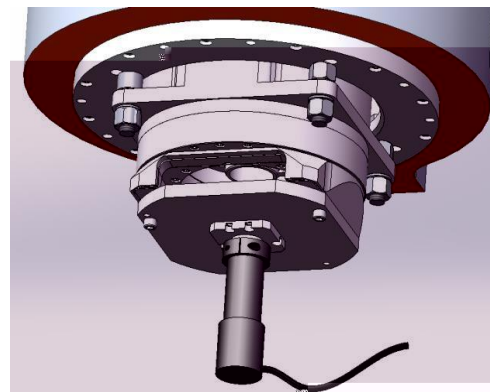
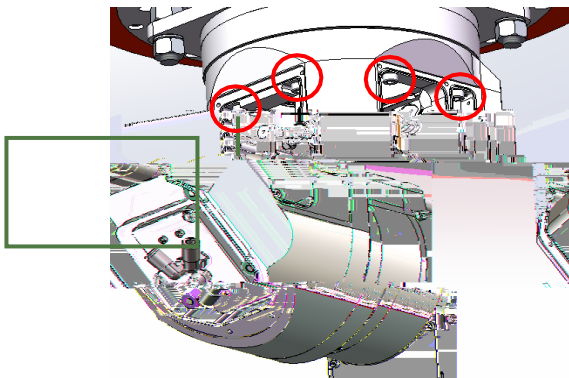

## 5.3.2 AO Mirror Adjustment



Caution: This operation requires lens tools and should be started after collimation leveling.

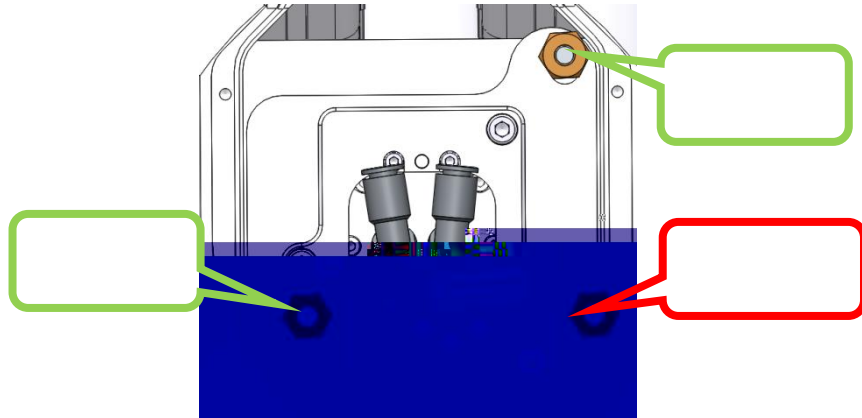

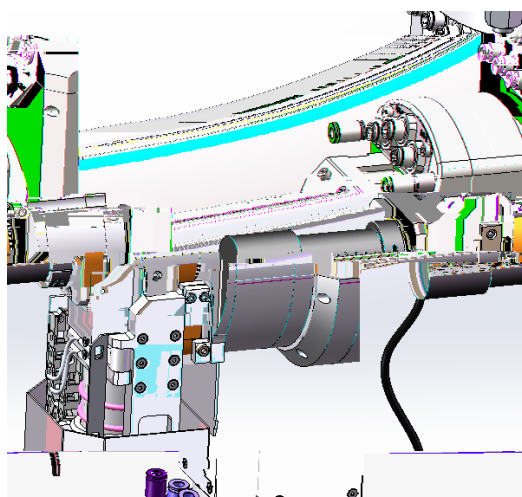

## 5.3.3 Focus Lens Alignment

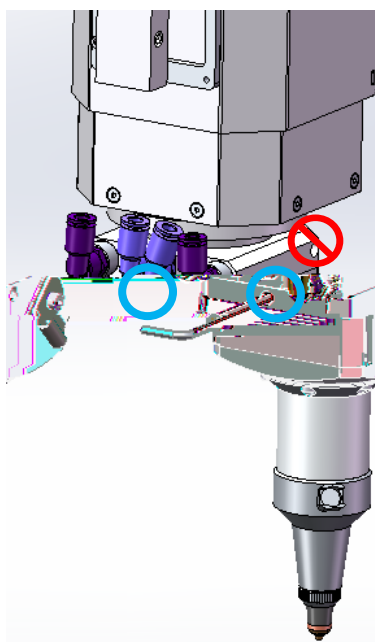

## 5.4 C-axis Zero Correction

### 5.4.1 Adjustment Preparation

### 5.4.2 Adjustment Method

## 5.5 A-axis Zero Correction

### 5.5.1 Adjustment Preparation

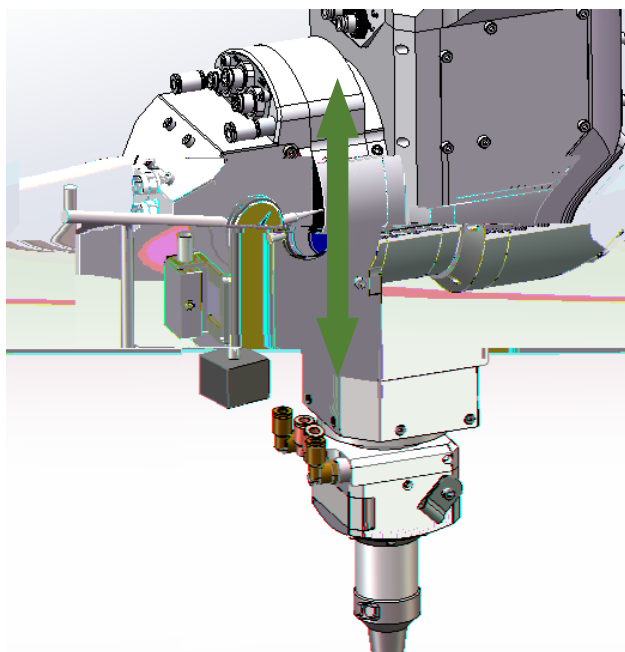

### 5.5.2 Adjustment Method

## 6. Function

$$\frac{1}{f_A} = \frac{3 - P}{7500}$$

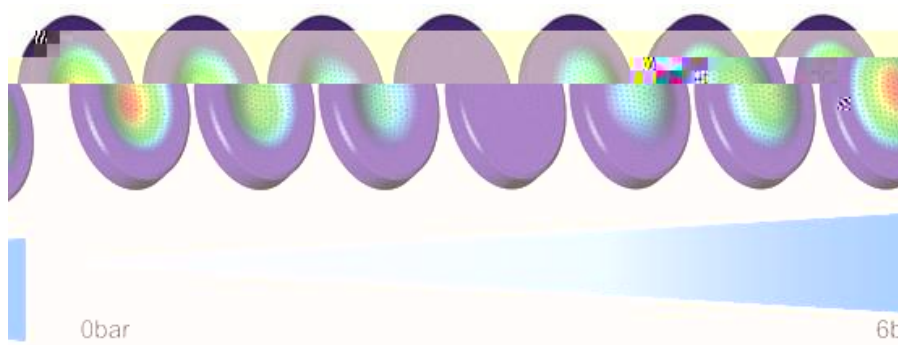

## 6.2 Anti-collision Mechanism



Caution: 1. In maintenance or mounting process, users should check if the sensor communicates properly with CNC controller, and if this safety function can stop running machine immediately when happen.

2. Collisions angle larger than  $6^\circ$  will cause irreversible damage to H-axis and bottom cover glass assembly.

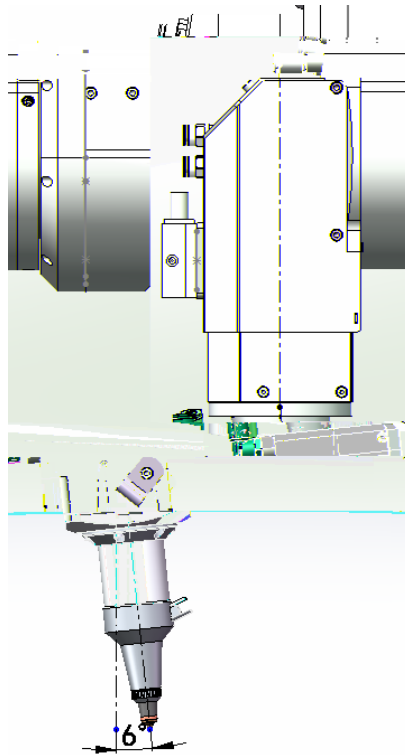

## 6.3 Gas and Water Interface

### 6.3.1 External Gas and Water Interface



Note: Do not run axes of the cutting head before connecting water cooling interface.

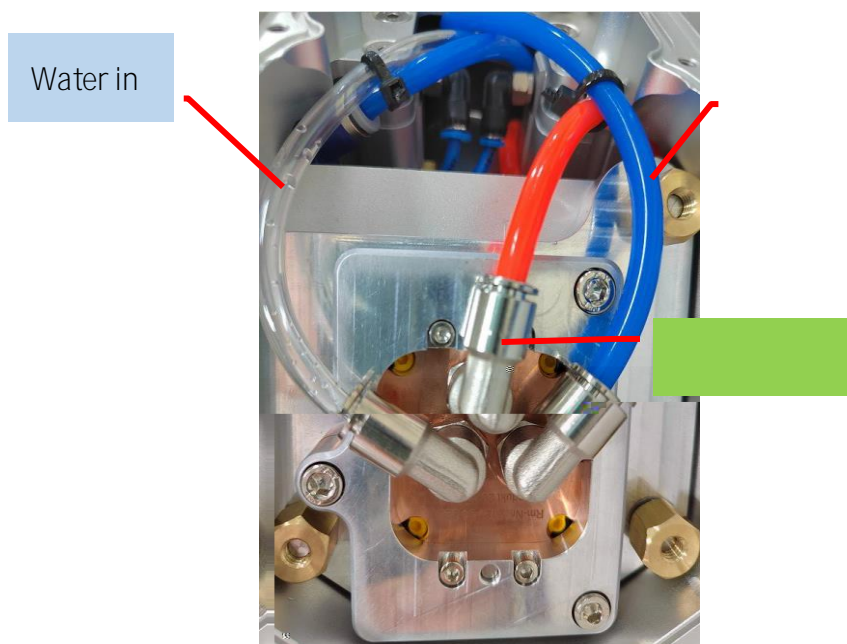

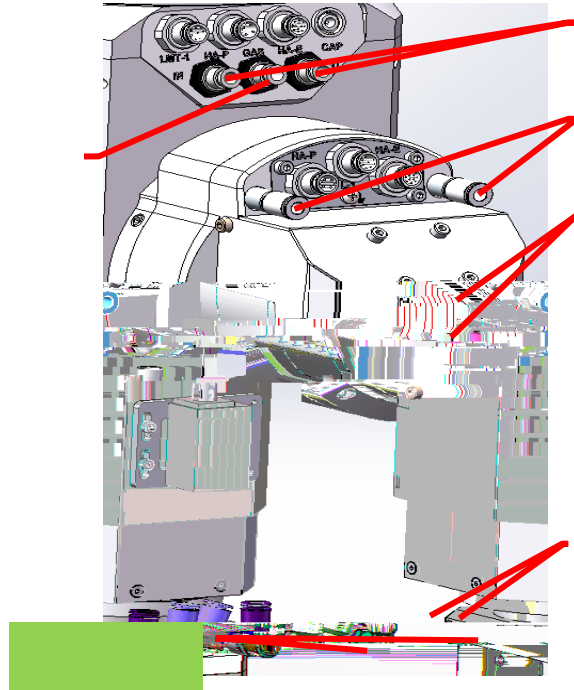

## 7. Motor and Encoder

### 7.1 C-axis Motor Datasheet

|  |  |  |
|--|--|--|
|  |  |  |
|  |  |  |
|  |  |  |
|  |  |  |
|  |  |  |
|  |  |  |
|  |  |  |

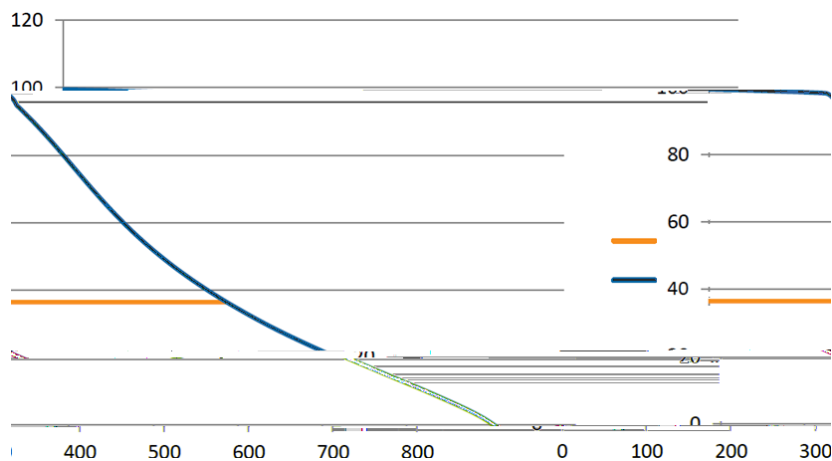

Max. speed of C-axis << Max. speed of motor



|  |  |  |
|--|--|--|
|  |  |  |
|  |  |  |
|  |  |  |
|  |  |  |
|  |  |  |
|  |  |  |
|  |  |  |

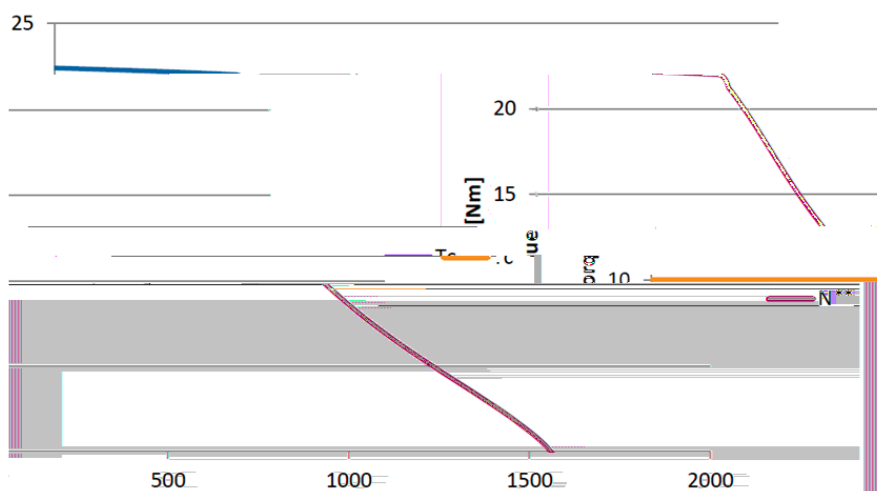

Max. speed of A-axis << Max. speed of motor

## 7.3 H-axis Motor Datasheet

|  |  |  |
|--|--|--|
|  |  |  |
|  |  |  |
|  |  |  |
|  |  |  |
|  |  |  |
|  |  |  |
|  |  |  |

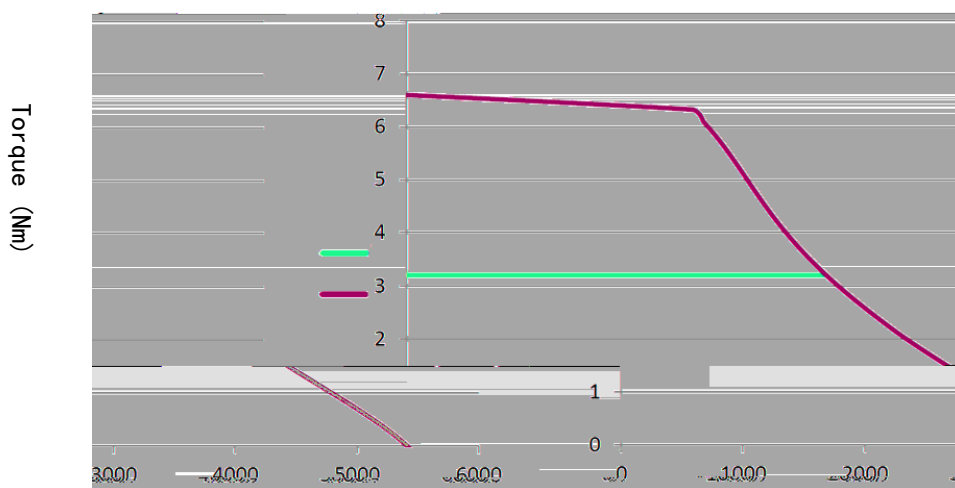

Max. speed of A-axis << Max. speed of motor

## 7.4 Encoder Data

## 7.5 Cut-off Temperature Sensor PTC and Temperature Monitoring Sensor KTY

|  |  |  |  |  |  |  |  |  |  |  |  |  |  |
|--|--|--|--|--|--|--|--|--|--|--|--|--|--|
|  |  |  |  |  |  |  |  |  |  |  |  |  |  |
|  |  |  |  |  |  |  |  |  |  |  |  |  |  |

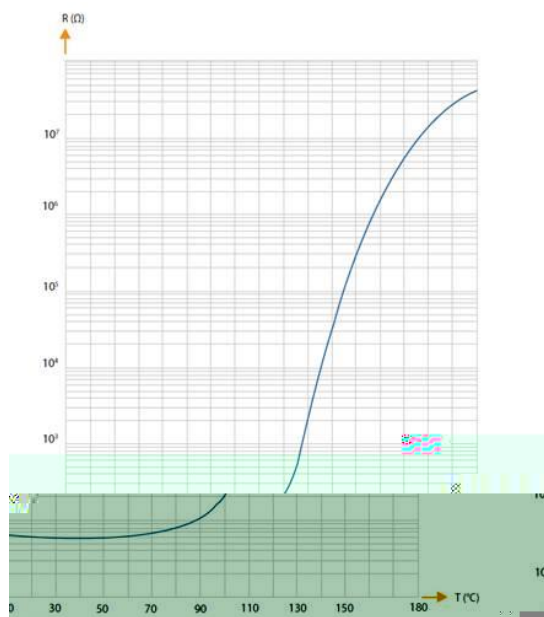
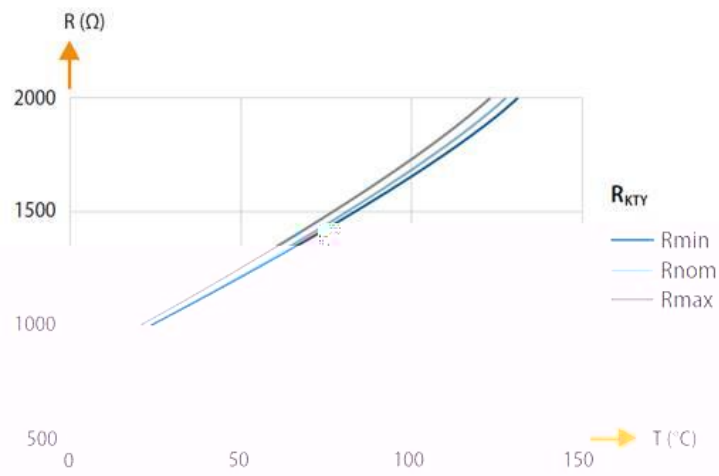

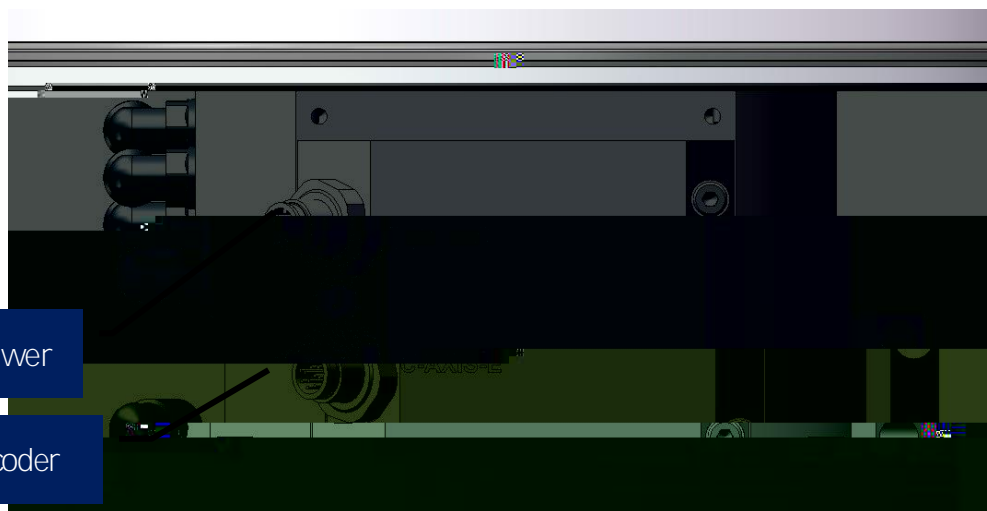
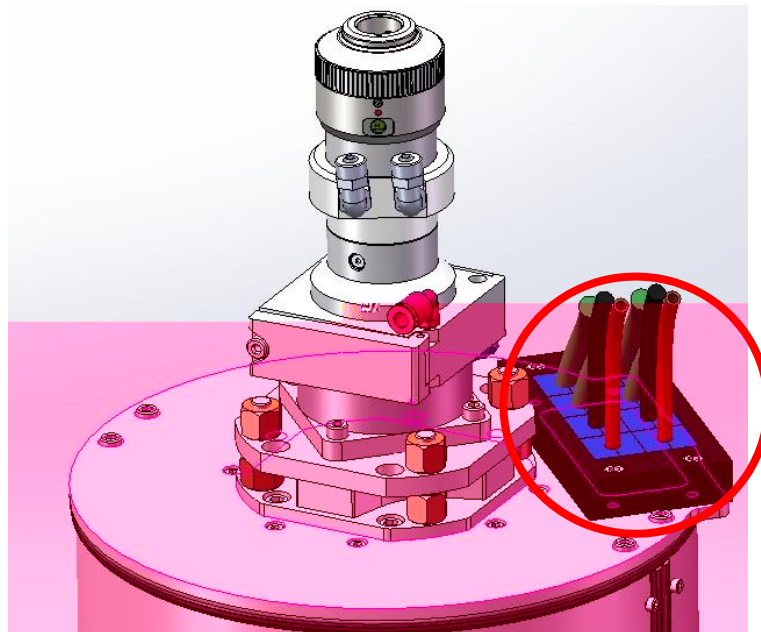

## 7.6 Connection of Electrical Interface and Cable

- 
- 
- 
- 



- .
- .
- .
- .

|  |  |   |
|--|--|---|
|  |  |   |
|  |  |  |
|  |  |   |
|  |  |   |

## 8. Troubleshooting

## 9. Maintenance

### 9.1 Maintenance List

|  |  |  |
|--|--|--|
|  |  |  |
|  |  |  |
|  |  |  |
|  |  |  |
|  |  |  |

### 9.2 Cleaning Lens

#### 9.2.1 Tools

#### 9.2.2 Cleaning Instruction

## 9.3 Removal and Installation of Collimation Module

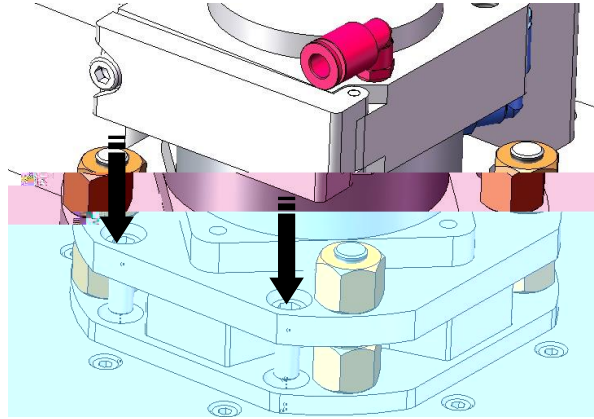

Warning: when moving the fiber, damage to the interface may cause the fiber to deflect. It's recommended to cover it with light shield.

Keep the lens holder upright while moving it to prevent the lens from falling off.

## 9.3.1 Removal and Installation of Collimation Lens

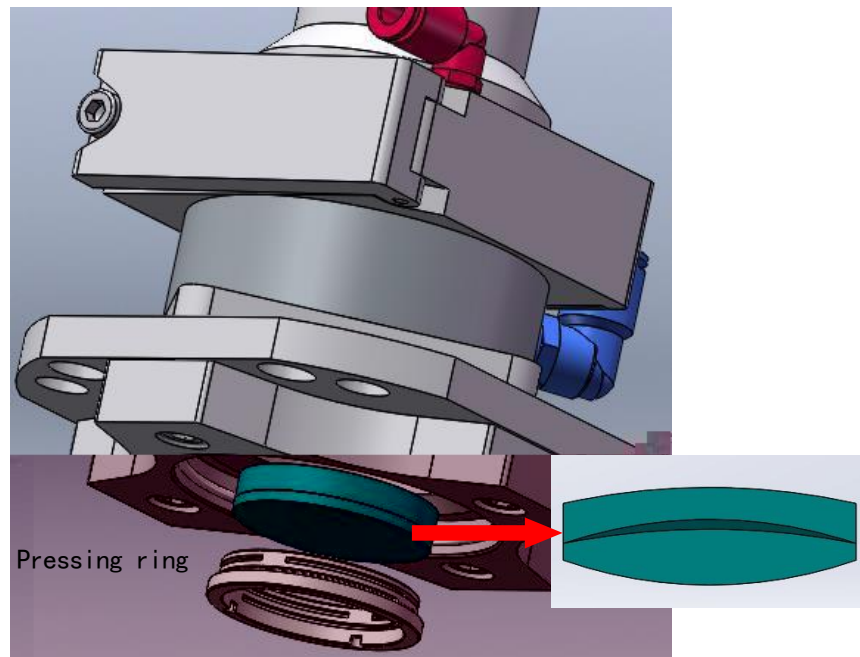
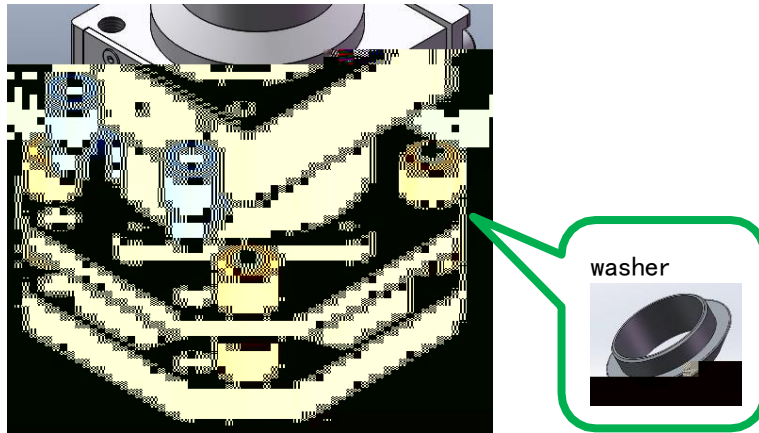

## 9.3.2 Removal and Installation of Top Cover Glass

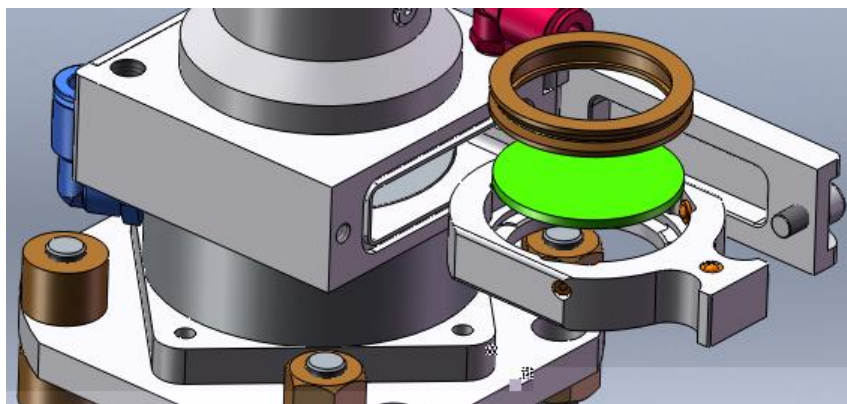

## 9.4 Removal and Installation of AO Mirror

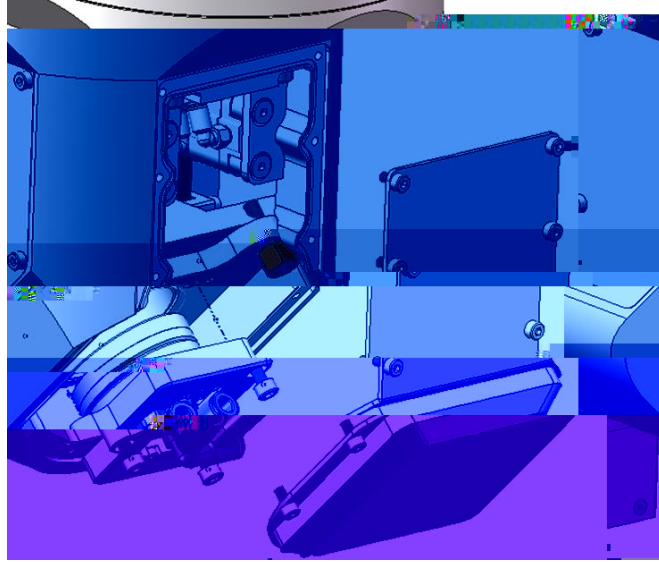

After replacing/cleaning AO mirror, please check if water pipes are properly connected and if there is water leakage.

## 9.5 Removal and Installation of Oblique Mirror

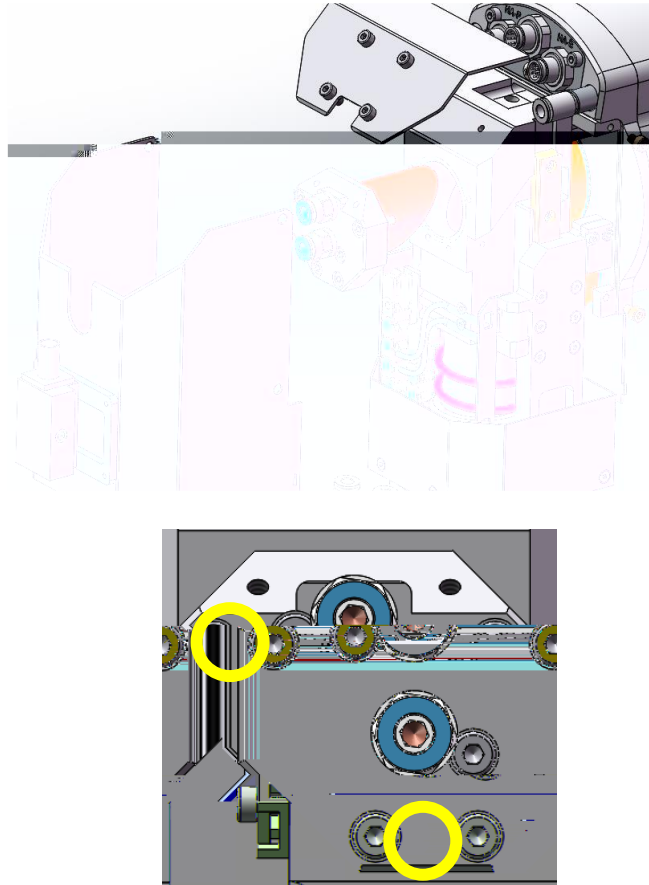

Note: The 2 bolts (red area) are used to fix the oblique mirror to the cover and must not be loosened before step 2, otherwise the oblique mirror may fall off. Both bolts can only be loosened when replacing oblique mirror.

## 9.6 Removal and Installation of Focus Module

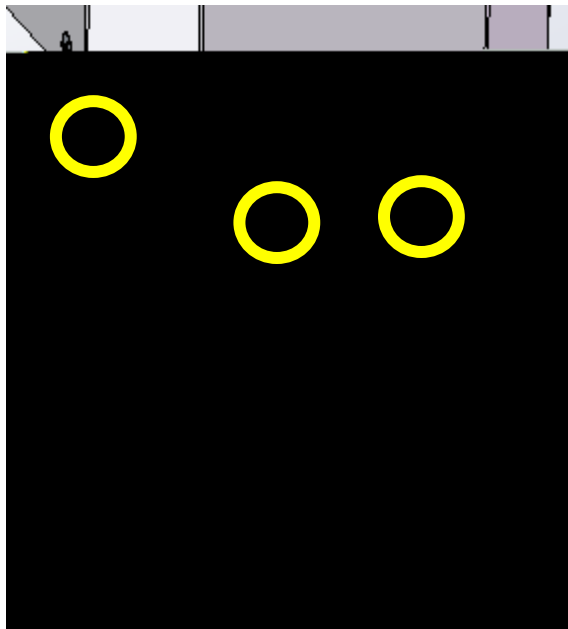

## 9.6.1 Removal and Installation of Focus Lens

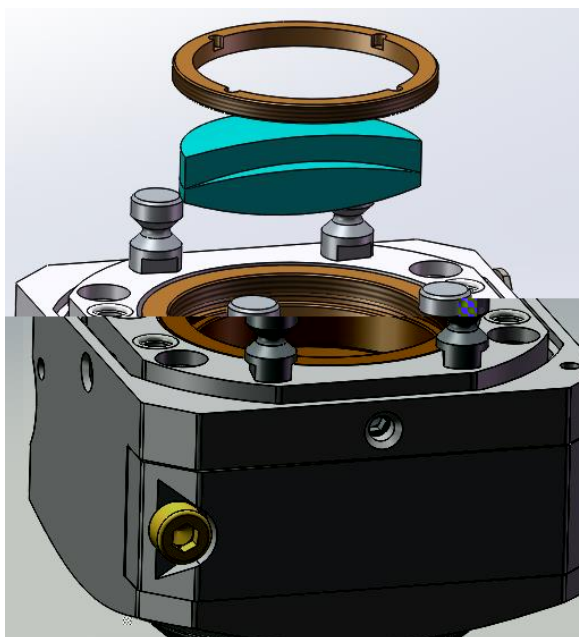

## 9.6.2 Removal and Installation of Bottom Cover Glass

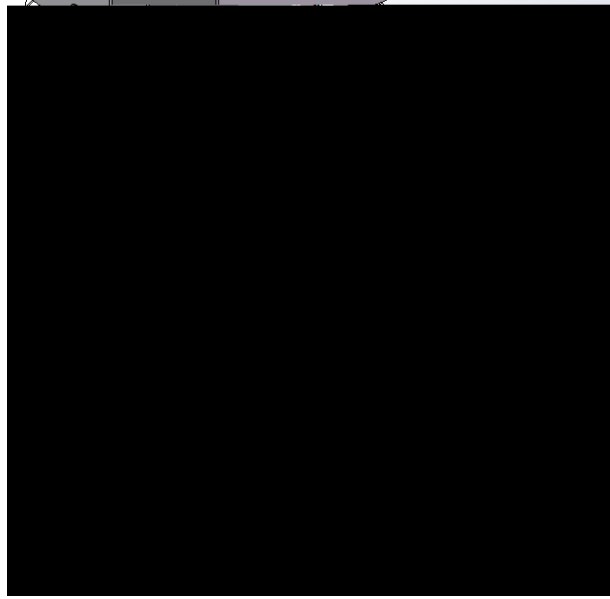

Note: It is forbidden to use nails or hard objects to directly remove the elastic seal ring above the cover glass, which will seriously cause damage to the elastic seal ring, air leakage or even damage to the cover glass, focus and collimation lens.

Keep seal ring properly as any small scratch will cause air leakage and affect the cutting effect.



## 10. Parts List

|  |  |  |
|--|--|--|
|  |  |  |
|  |  |  |
|  |  |  |
|  |  |  |
|  |  |  |
|  |  |  |